

Hoofdkantoor Oirschot
Westfields 1210
5688 HA Oirschot

✉ verkoop@ecr-nederland.nl

☎ +31 (0)88 299 06 00

Airconditioning Comfort & Process Chillers
The new era of natural refrigerants
Starting from 190 up to 1400 kW for air conditioning
and from 100 up to 765 kW for process cooling

New Horizon NH₃ Standard Line
Innovative technology and high efficiency performance
Industrial grade design and build quality
Designed by SCM Ref

Standaard NH₃ Chiller



1

Beijer Ref Group introduction

Page 3

2

Benefit of ammonia

Page 7

5

Maintenance features

Page 10

3

Natural refrigerants

Page 8

4

Safety features

Page 9

Content:

1. Beijer Ref Group introduction

The Beijer Ref Group, head-quartered in Malmö Sweden is one of the world's biggest distributors of HVAC&R technologies.

2. Benefits of ammonia

Ammonia for refrigeration (NH_3) is an important tool in large commercial and industrial application. It is efficient, cost-effective and good for the environment.

3. SCM Ref embraces natural refrigerants

Ammonia has been an ideal refrigerant for our industry because it is very energy-efficient, cost-effective and safe.

4. Safety features

The chillers design is compact with a hermetically factory welded closed circuit.

5. Maintenance features

SCM REF ammonia chillers are designed to be service friendly. The components are arranged in a well-thought-out way to make sure their accessibility.

6. Ammonia, what else?

Why chose for natural refrigerants Natural refrigerants, carbon dioxide, ammonia and hydrocarbons have been successfully used in different large air conditioning.

7. Main components

The units are plug and play prepared in the factory and easy to install and commission on site.

Page 3

Page 7

Page 8

Page 9

Page 10

Page 11

Page 13

6

Ammonia, what else?

Page 11

8

Page 15

Chiller categorization

9

3D modelling

Page 16

7

Page 13

Main components

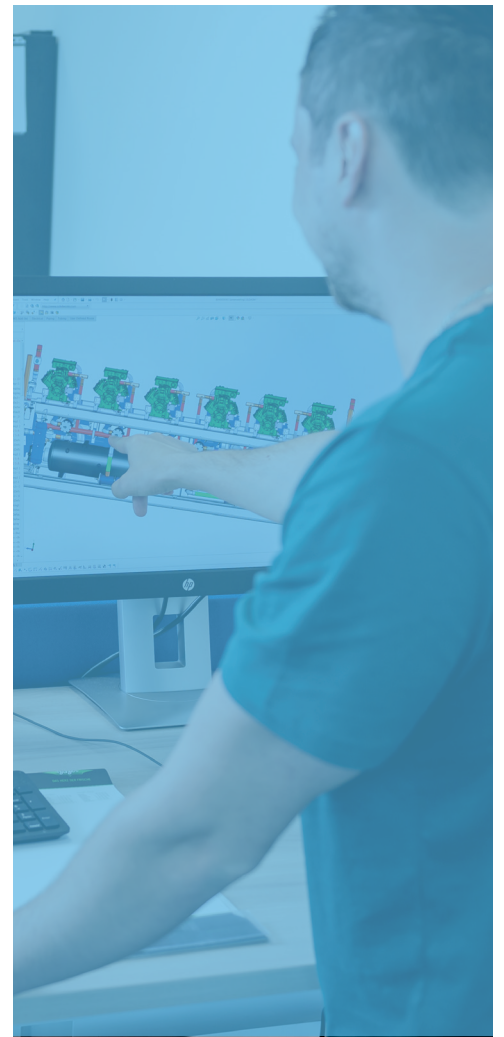

8. Chiller categorization

Page 15

Check out our naming system.

9. 3D modelling

Page 16

We have put together some 3D models.

- 9a. Technical data - Airconditioning comfort Chiller with air-cooled condensor
- 9b. Technical data - Airconditioning comfort Chiller with water-cooled condensor
- 9c. Technical data - Proces Chiller with air-cooled condensor
- 9d. Technical data - Proces Chiller with water-cooled condensor

Chapter 1.

Beijer Ref Group introduction

The Beijer Ref group, head-quartered in Malmö Sweden is one of the world's biggest distributors of HVAC&R technologies. The company's expansion strategy is twofold: to enlarge the geographical land-scape and to harmonize the product portfolio and the production. The company intends to produce, as an OEM, at several locations around the world, and to sell the portfolio worldwide. The company is convinced and optimistic that the demand for the use of natural refrigerants will grow. Beijer Ref is therefore keen to enlarge its natural refrigerant portfolio. It is this desire to be at the forefront of new technology development that drives the company's expansion.

Beijer Ref is committed, determined and united in its future strategy. The company is a market leader on green solutions. It is in its culture and DNA to care about protecting the environment. As a Swedish company Beijer Ref defends these values within the industry.



Beijer Ref Support Center. Is a Beijer Ref company. Its head office in Oirschot, the Netherlands is known as the Beijer Ref Support Center. The Center was custom built to Beijer Ref's requirements and has a total space of 12500 square meters. It is a state of the art building that is equipped with the latest sustainable and energy efficient features for its; offices, warehouses and production facility.

As we can derive from the name, it is a support center for the Beijer Ref companies.

- The Beijer Ref Support Center, which utilizes the back office and the general warehouse for the Beijer Ref independent sales companies.
- SCM Ref production facility for the packaged units and racks.
- The Beijer Ref Academy which is focused on developing 'best practice' knowledge about our innovative technology's for ammonia and other natural refrigerant packaged units. Supporting our partners and customers with dedicated training programs.



SCM Ref BV is the independent assembly facility for the Beijer Ref companies. Experienced in Industrial grade design and build quality. They are specialized in the design and building of ammonia packaged units and have supplied numerous custom made racks, which have been dispatched to Beijer Ref customers worldwide.

All our units are produced according our integrated quality system, with certified personnel for the application of the F-gas directives and PED type approval up to category IV. The units are CE compliant adhering to the Machinery, Pressure equipment, Low voltage, EMC and the Eco design directives.

Within our own test facilities, we can safely pressure test our units. We have a shielded room of 10 x 10 meters. The operations of that area are performed from a separate adjacent room, from which all equipment can be safely tested.

Our maximum building height is 10 meters. We can produce high cascade units in one piece. We are equipped with the most up to date equipment and tools for producing high standard units.

Our modern production facility has a central exhaust system for smoke and toxic gases. This is equipped with a high-efficiency flue gas filter. The warm air is not discharged outside but is purified and returned into the interior. This saves heating capacity. In summer, the cooled air is also returned to the interior in the same way again saving energy.





Key Benefits Chiller Line:

- Standardized Industrial grade design and build quality
- Future safe Low charged natural ammonia (R717) refrigerant
- SCM Semi-hermetic sealed compressor and hermetic welded circuit
- Innovative technology and high efficiency performance
- Plug & Play installation and commissioning, low maintenance, service friendly

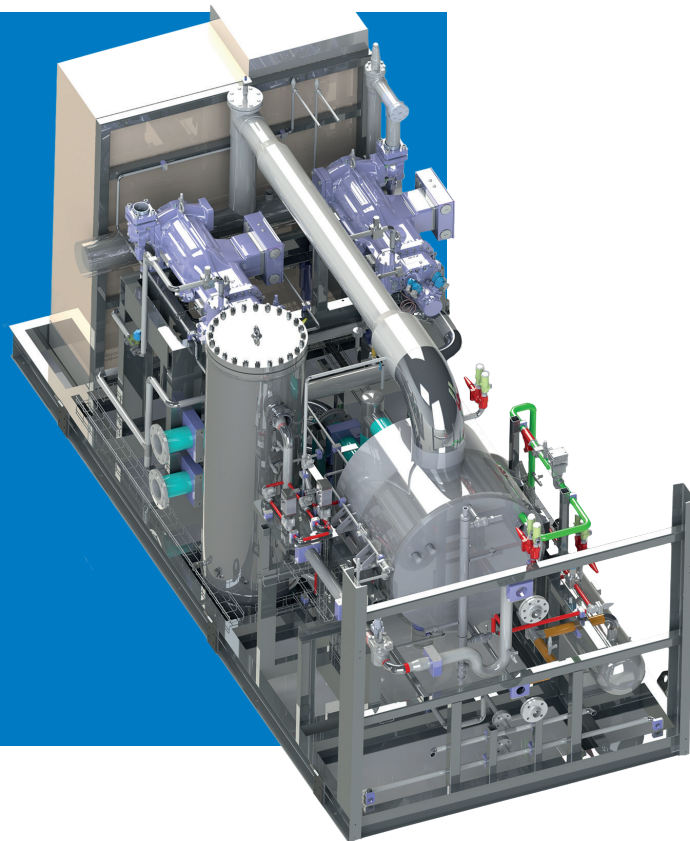



Key benefits of ammonia

Natural ammonia is the key for future safe and sustainable air-conditioning and refrigeration.

1. Ammonia is environmentally compatible. It does not deplete the ozone layer and does not contribute to global warming.
2. Ammonia has superior thermodynamic qualities. Which result in ammonia refrigeration systems being the most efficient for comfort and process Chiller applications.
3. Ammonia's recognizable odor is its greatest safety asset. Most other natural hazardous refrigerants that have no odor, ammonia refrigeration has a proven safety record in part because leaks are unlikely to escape detection.

Safety aspect of ammonia

Ammonia fumes are toxic, Ammonia is relatively safe from explosion hazards and classified as low flammable gas (B2L).

SCM REF ammonia chiller line -with its high efficiency and built-in safety features- makes it unprecedentedly easy and safe to adopt ammonia chillers. However, handling ammonia does require training, and safety precautions, and you should always use trained staff for inspections and trusted refrigeration services for maintenance.

Chapter 3.

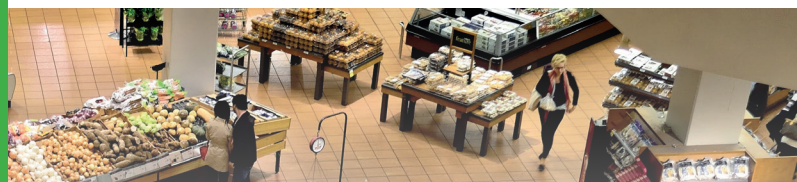

SCM REF embraces natural refrigerants

Ammonia has been an ideal refrigerant for our industry because it is very energy-efficient, cost-effective and safe. Even better, it contributes to slowing down global warming effect because it has zero negative impact to environment and protect our common home, Earth.

There are two Chiller lines. Each for a specific application and always using glycol or another secondary coolant to deliver comfort and cooling to the process.

1. Comfort air conditioning for people in residential-, public service-, healthcare-, commercial-, sports-, office-, and other buildings.
2. Cooling at medium low temperature for all type of commercial or light industrial refrigeration processes.

The Chiller rack in combination with a bespoke air-cooled condenser and oil cooler can be installed outside on the roof, eliminating the need for an engine room. For an indoor application the Chiller is equipped with a water-cooled condenser integrated in one rack. However, both air cooled and water-cooled Chiller racks can be placed either indoor or outdoor. Well thought designed and robust quality ensures smooth operation in extreme weather conditions and environment.

Standard Chiller Line	Airconditioning comfort at +12 / +7°C	Medium temp process at -3 / -8°C
Air cooled condenser at +35°C ambient	190 - 960 kW	100 - 515 kW
Water cooled condenser at +30 / +35°C water	300 - 1.385 kW	165 - 765 kW

Deployable with a digital and analog setpoint shift to comply with wide application range.

- Air conditioning chiller set point shift allows water outlet temperature set between +4°C and +10°C.
- Process chiller set point shift allows glycol outlet temperature set between -2°C and -11°C

Operating under varying load conditions the smart capacity control software manages the compressor slider control solenoid valves and frequency inverter to provide minimum energy consumption at optimal COP.

Chapter 4.

Safety features

The chillers design is compact with a hermetically factory welded closed circuit. The leakage from shaft seal being eliminated completely by using semi-hermetic compressor.

Dedicated Siemens S7 software can regulate by itself without human intervene during normal situation. Multiple safety prevention mechanisms are already tested and built in to sustain operation in difficult situations and prevent damage in emergency. Such as the fail safe pump down function against blow-out of ammonia.

HP and LP pressure switches are installed as standard. Dual safety relief valves are welded on each pressure vessel. The optional safety relief valves are connected to one common relief pipe.

Ammonia detector and alarm are built into all chiller models and powered by independent supply. To help our customers comply with different local legislation, the detection level can be adjusted. The sensors are pre calibrated over the full range. The temperature and humidity inside the electrical switch box is monitored and controlled to minimize the environmental influence and work in a wide temperature range from -5 up to 40°C and 85% relative humidity. For low temperature applications an additional heater is available as an option.



Chapter 5.

Maintenance features



SCM REF ammonia chillers are designed to be service friendly. The components are arranged in a well-thought-out way to make sure their accessibility.

All major components can be isolated by ball valves easily.

Each oil filter can be easily isolated and allow continuous operation during service. The connecting pipes where oil filters are installed, are designed to be short as possible.

A hand drain valve is installed at the bottom of evaporator for checking or draining oil. For air cooled condensers, each fan is equipped with a service switch

Chapter 6.

Ammonia, what else?

Why chose for natural refrigerants? Natural refrigerants, carbon dioxide, ammonia and hydrocarbons have been successfully used in different large air conditioning and refrigeration applications for many years. But with the exception of a few sectors, their market penetration has remained relatively low.

Today this is changing fast, the evolving legislative demands on the use of fluorinated refrigerants, the proactivity of influential end users and the reduction of technology costs are driving the wider use of natural refrigerants worldwide.

The SCM Ref standard Chillers can help open up ammonia to new areas of application including, for example, air conditioning for residential buildings and cold generation for large distribution centers and supermarkets.

NH₃ is the only refrigerant with zero ozone-depleting potential and zero global warming potential.

Our mascot 'The Whale'

Our aim to reduce the carbon footprint with our Innovative technology and high efficiency NH3 Chillers is one step towards the solution. Another one is found in Nature's Solution to Climate Change. Whales absorb more carbon than rain forests and help produce half of the planet's oxygen supply. One whale is worth thousands of trees.

The Carbon sink

Whales accumulate carbon in their bodies during their long lives. When they die, they sink to the bottom of the ocean; each great whale sequesters 33 tons (30.000kg) of CO2 on average, taking that carbon out of the atmosphere for centuries. A tree, meanwhile, absorbs only up to 48 pounds (20 kg) of CO2 a year. This is only the beginning of the story.

The whale pump

Wherever whales, the largest living things on earth, are found, so are populations of some of the smallest, phytoplankton. It turns out that whales' waste products contain exactly the substances phytoplankton need to grow. Whales bring minerals up to the ocean surface through their vertical movement, called the "whale pump," and through their migration across oceans, called the "whale conveyor belt ". Preliminary modelling and estimates indicate that this fertilizing activity adds significantly to phytoplankton growth in the areas whales frequent visit.

These microscopic creatures not only contribute at least 50 percent of all oxygen to our atmosphere, they do so by capturing about 37 billion metric tons of CO2, an estimated 40 percent of all CO2 produced. To put things in perspective, we calculate that this is equivalent to the amount of CO2 captured by 1.70 trillion trees, four Amazon forests' worth. More phytoplankton means more carbon capture.

This information was taken from an article in the FINANCE & DEVELOPMENT Magazine, December 2019, 56, NO. 4 interview with Ralph Chami, Sena Ozzosun, Thomas Cosimano and Connel Fullenkamp.



Chapter 7.

Main components

The units are plug and play prepared in the factory and easy to install and commission on site.

1

Cutting-edge semi-hermetic ammonia screw compressors with internal high efficiency permanent magnetic motor. The build is compact and there is no open-type shaft seal. This eliminates the risk on ammonia leakage and reduces the downtime significantly. The standard Chiller racks also provides the option for an open-drive ammonia compressor. For details see the folder "SCM Ref Standard air conditioning & Process Chillers, Open type compressor".

2

The three-stage oil separator is exceptionally efficient through the complete range of capacities and discharge gas velocities, separating the discharged oil from the screw compressor and returning it to the compressor after cooling down. The minimum amount of oil entering the refrigerant circuit is returned through an automatic controlled bleeding system.

3

The horizontal or V-shaped layout air cooled condensers are equipped with EC axial fans and designed with integrated oil cooling loop. The Chiller rack is Plug & Play prepared for connection to the dedicated condenser frame by robust prefabricated piping including flange connections. Eliminating any welding activity on site.

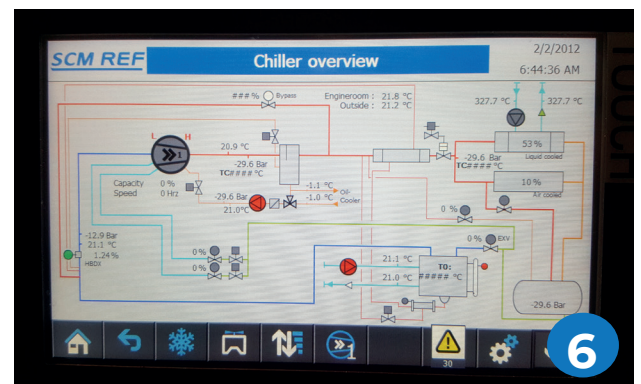
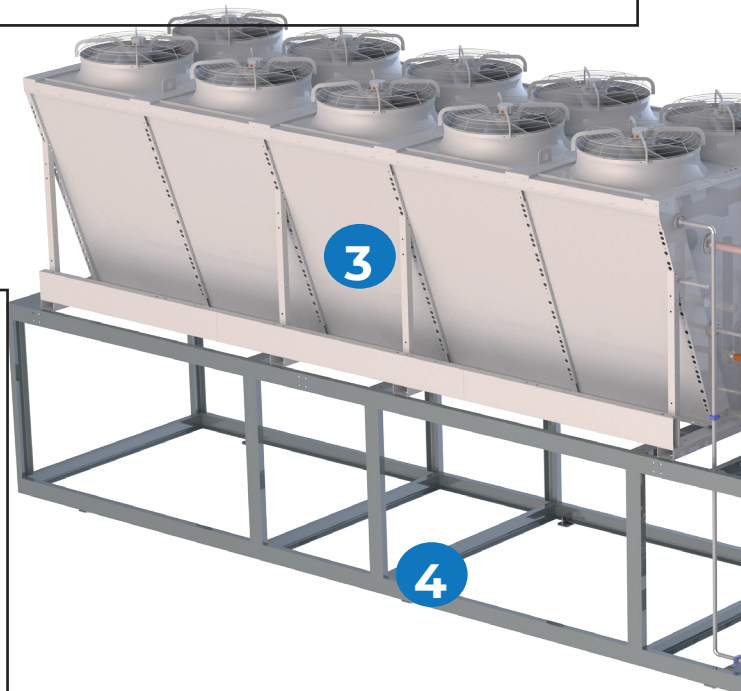

4

SCM REF ammonia chillers are combined with air cooled or water-cooled condensers. Air cooled chiller includes two racks, which can be placed together outside or separately, chiller rack indoor and air-cooled condenser outdoor. The water-cooled chiller is installed as one compact rack. Outdoor positioned chillers are protected by strong industrial grade casings. They are designed to be weather proof, suitable for industrial and marine environments. Explosion-proof exhaust fans are provided as standard. Options for sound absorbing casing, internal mechanical cooling are available.

5

The compact and robust plate-in-shell heat exchangers are designed to be optimized for chiller application with stable thermal performance under different load conditions. Optional to configure for secondary constant and variable speed pumps. The patented plate profiles have been utilized for their proven high thermal performance.

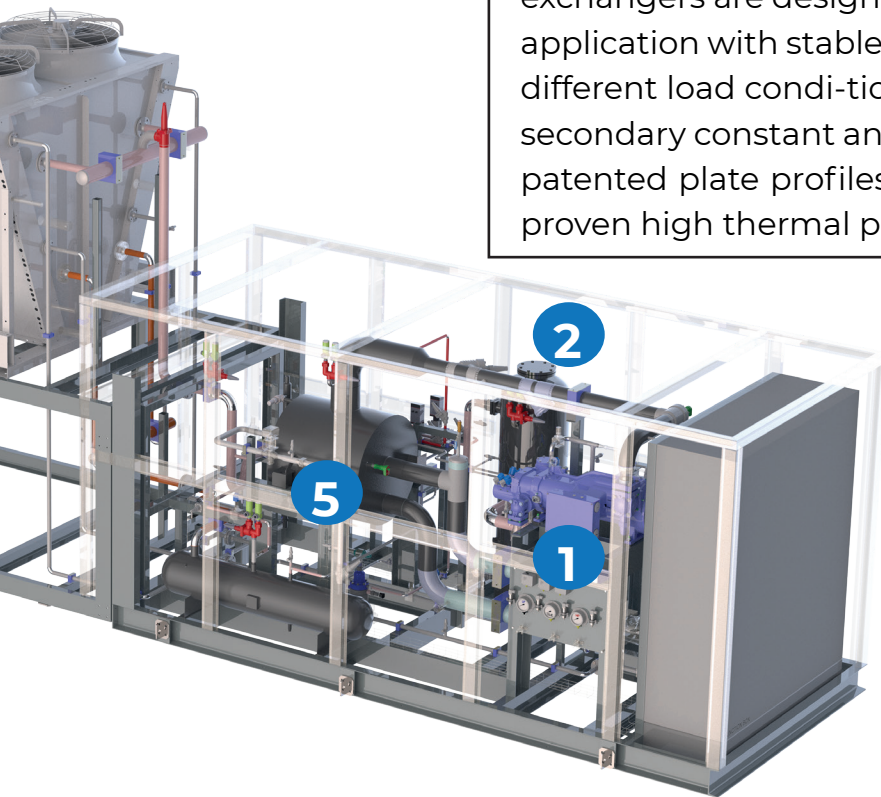

6

The highly automated control system has many safety mechanisms embedded, which work in harmony with an SMC SCM Ref developed chiller control software. The flow diagram and functions are clearly displayed on a full color 7" LCD touchscreen. The sophisticated control scheme has been developed by engineers with many years of field experience to prevent many possible issues. We make these chillers to be safe and easy to use. A router suitable for wired, Wi-Fi or 4G internet connection is integrated.

Chiller categorization

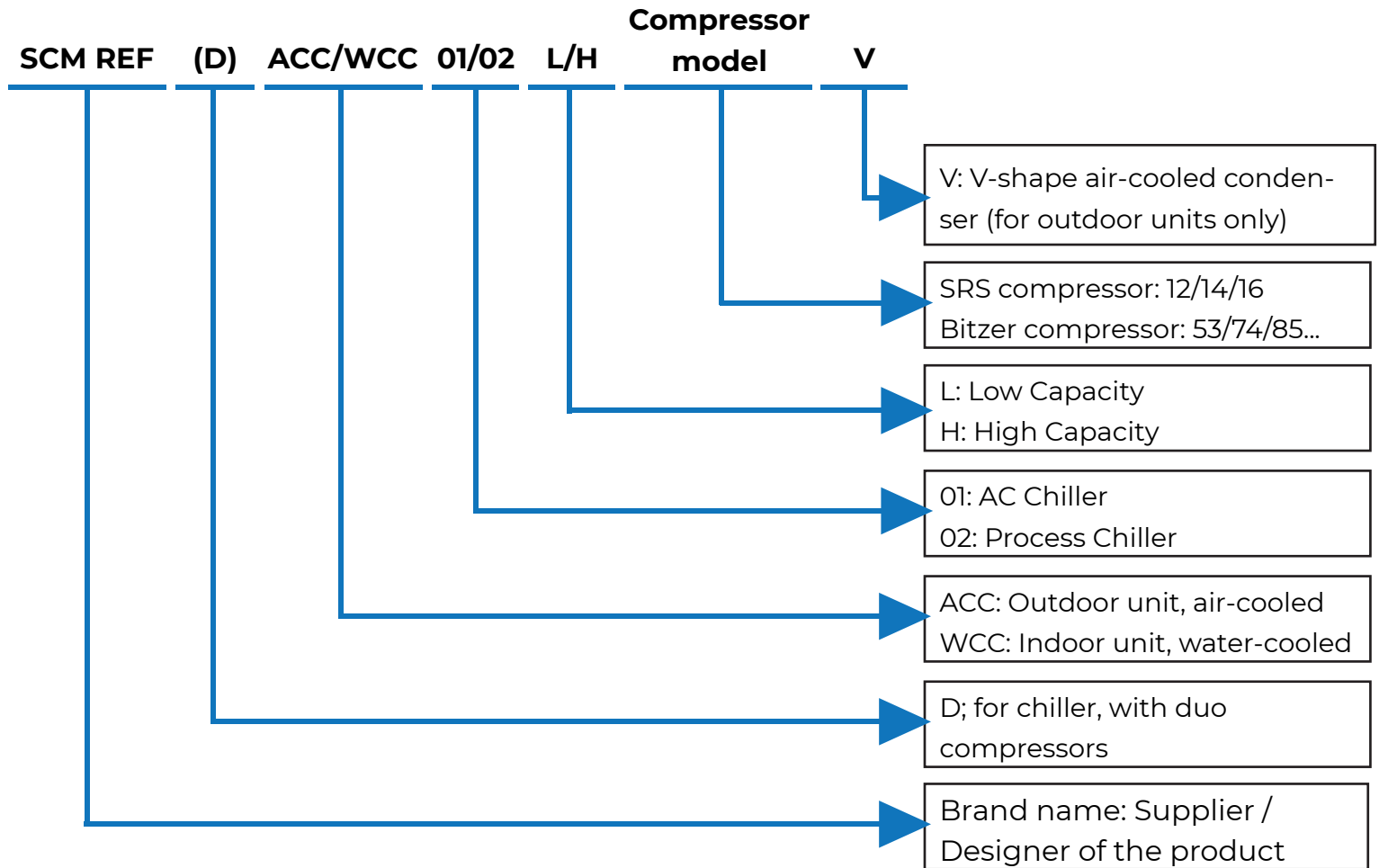

Application	AC comfort chiller and medium temperature process cooling.
Option 1	Winter package for extreme low ambient temperature.
Option 2	Weather casing with mechanical ventilation. ATEX fans.
Option 3	Closed casing with sound-proof panel, mechanical cooling and NH3 blow out. ventilation. ATEX fans.
Option 4	General exhaust pipe connecting all relief valves to the outside of casing.
Option 5	Liquid injection for oil temperature protection.
Option 6	3-way regulating valve at water inlet connection for head pressure control of water-cooled condenser.
Option 7	Hybrid air-cooled condenser/dry cooler are available for air-cooled/water-cooled chillers. Please contact SCM Ref for details.
Option 8	Adaption to NH3 CO2 application on request.

Chapter 9.

3D modelling

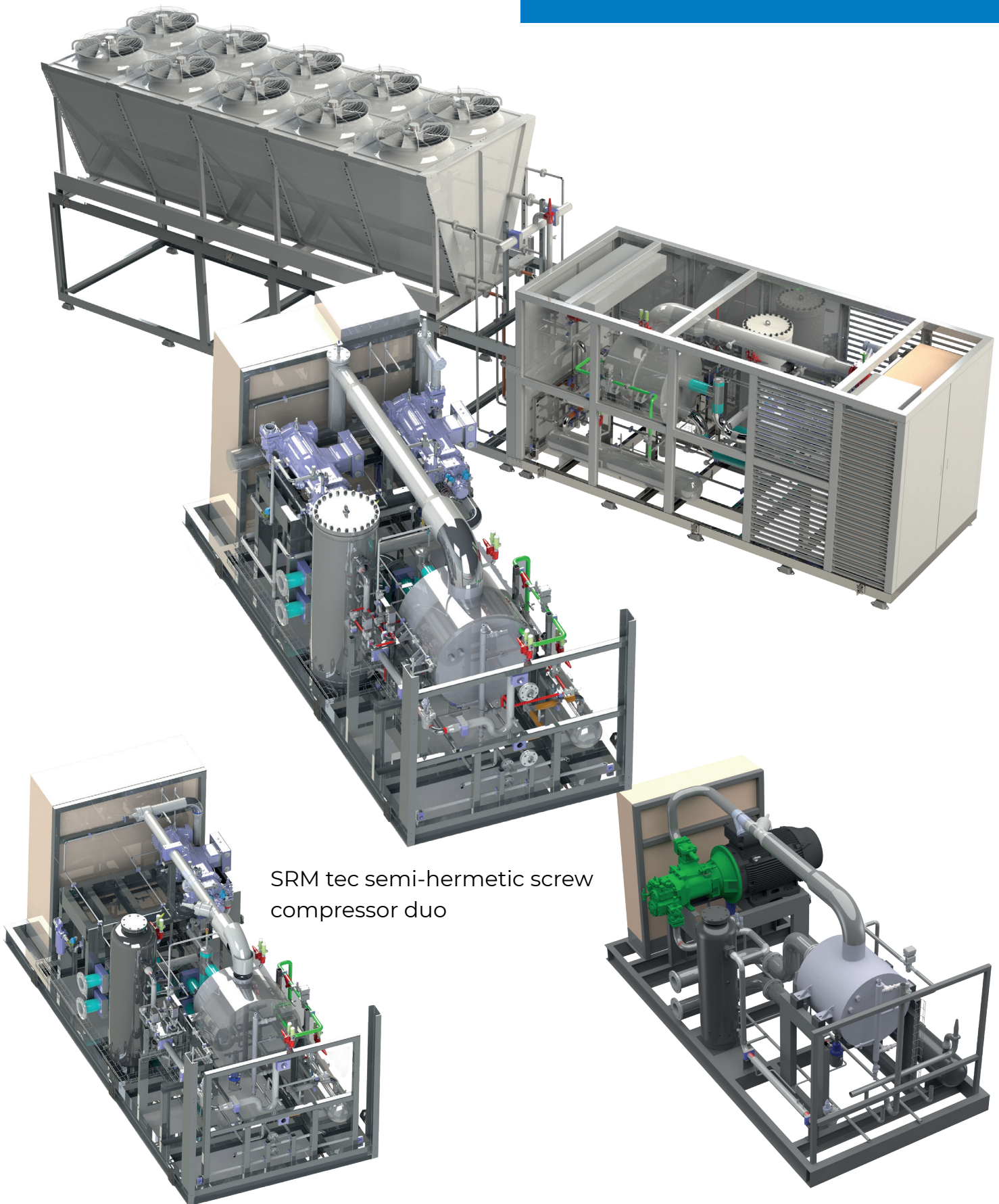

SRM tec semi-hermetic screw compressor duo

SRM tec semi-hermetic screw compressor single

Bitzer open screw compressor

Technical data Airconditioning comfort Chiller with air-cooled condensor

Electric & Performances						
Application	Air conditioning comfort Chiller Water-MEG mixture 15% *(1) inlet / outlet +12°C / +7°C			With air cooled Condenser Air cooled @ Ambient Max.+35°C		
	Description Chiller		Electrical data	Performance data *(2)	Chiller	
Model *(3)	Compressor	Speed	Fuse size (A)	Qo. (kW)	Flow (m ³ /h)	Δp (KPa)
ACC 01 L12	Single	Low	250	190	32,5	15
ACC 01 H12	Single	High	400	319	54,5	15
ACC 01 L14	Single	Low	400	285	48,7	15
ACC 01 H14 V	Single	High	500	478	81,8	15
D ACC 01 L12 V	Duo	Low	500	379	64,9	31
D ACC 01 H12 V	Duo	High	500	637	109,1	32
D ACC 01 L14 V	Duo	Low	800	569	97,4	32
D ACC 01 H14 V	Duo	High	800	956	163,6	32

*(1) Advised to use Water Ethylene Glycol mixture for protection against frost (-3,5°C). Also suitable for other coolant fluids s.a. CaCl₂, ammonia-water and other industrial brines.

*(2) Cooling capacity at nominal saturated evaporation and condensing temperatures +4/+45°C. (R717). Performances are based on compressor manufacturer data that comply with EN12900 standard. See the chiller envelope for the full temperature range application.

*(3) For Semi Hermetic type compressor SRM tec screw. Single versions also available with open type compressor Bitzer screw.

- Digital and analog setpoint shift available to comply with wide application range.
- AC chiller set point shift allows water/glycol outlet temperature set between +4°C and +10°C.
- Power supply 380/400V-3-50 Hz. Cabinet includes isolated transformer. No neutral leader required



Dimensions and Weight								
Application	Air conditioning comfort Chiller				With air cooled condenser			
Description Chiller	Length (mm)	Width (mm)	Height (mm)	Weight (kg)	Length (mm)	Width (mm)	Height (mm)	Weight (kg)
Model *(3)	L1	W1	H1	M1	L2	W2	H2	M2
ACC 01 L12	5300	2250	2615	4347	6000	2250	2835	930
ACC 01 H12	5300	2250	2615	4378	8000	2250	2835	1790
ACC 01 L14	5300	2250	2615	4551	8000	2250	2835	1370
ACC 01 H14 V	5300	2250	2615	4704	8000	2250	4115	3200
D ACC 01 L12 V	5300	2250	2615	5442	8000	2250	4115	3400
D ACC 01 H12 V	5300	2250	2615	5690	12000	2250	4115	4480
D ACC 01 L14 V	5300	2250	2615	5943	12000	2250	4115	3840
D ACC 01 H14 V	5300	2250	2615	6070	12000	2250	4115	5120

- Dimensions in the table above are with casing included. The top cover is demountable to fit into a container.
- Orders with casings will be delivered with absorption dampers dismounted.

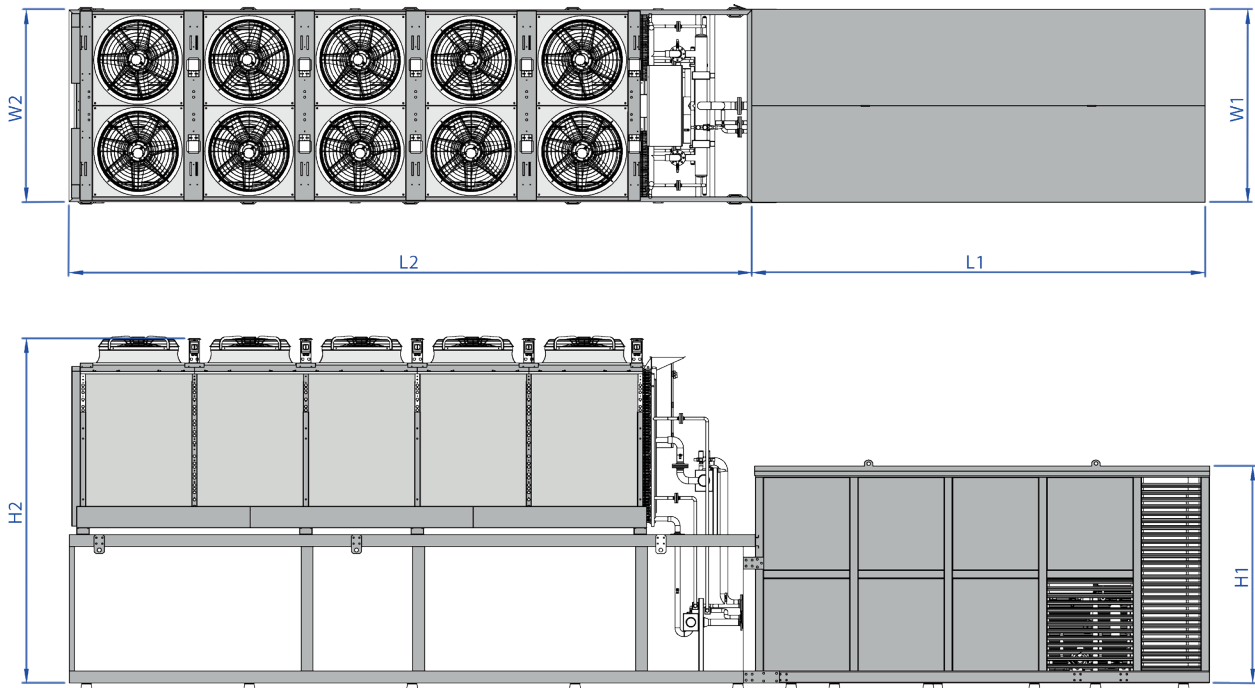

*Air-cooled condenser is connected and mounted with prefab piping and framework.
 *Air-cooled can be delivered separately without framework. Prefabbed Inlet/outlet headers, service valves, double safety valves will be delivered. X-ray is not needed.

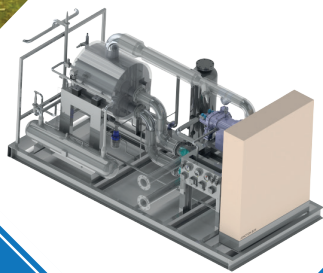

Contact

Hoofdkantoor Oirschot

Westfields 1210, 5688 HA Oirschot
+31 (0) 88 299 06 00
verkoop@ecr-nederland.nl

Breda

Princenhagelaan 1C3
4813 DA Breda
+31 (0) 88 299 06 90
breda@ecr-nederland.nl

Hoofddorp

Parellaan 60
2132 WS Hoofddorp
+31 (0) 88 299 06 80
hoofddorp@ecr-nederland.nl

Deventer

Danzigweg 6a
7418 EN Deventer
+31 (0) 88 299 06 70
deventer@ecr-nederland.nl